



Double Flanged Sluice Valves

(NRSV & RSGV)

Sluice Valve is the most populous & relied upon water-works valve since decades. R&D Multiple's Sluice Valves are consciously built to fulfill customer's expectations & faith. They not only comply with the requirements of the specifications & codes, but also offer features, accessories, quality & workmanship levels which make them the unique choice for any waterworks isolation application.

NON RISING STEM SLUICE VALVE WITH HANDWHEEL

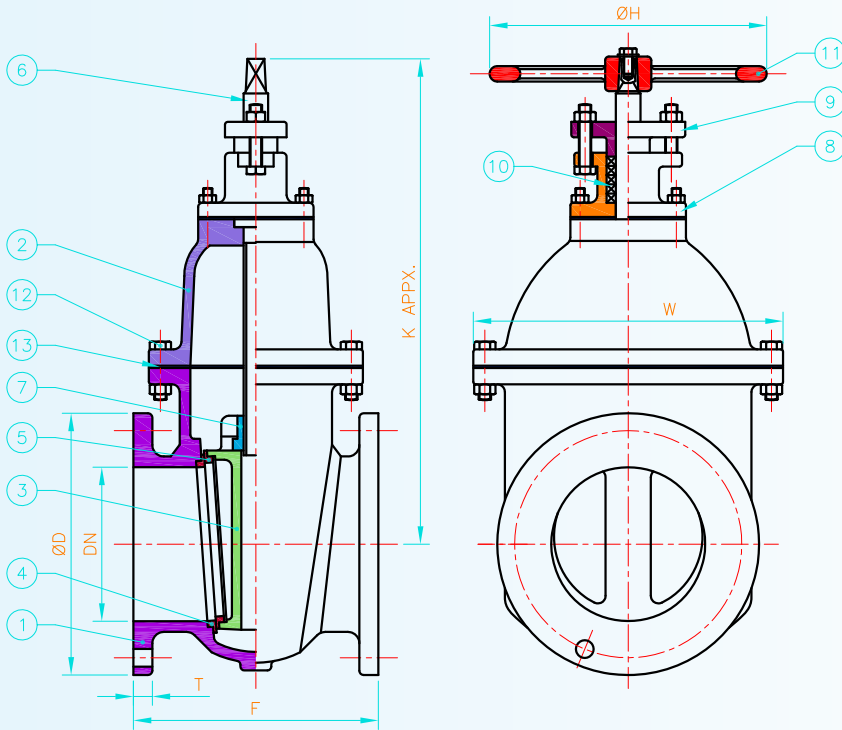

NO.	PART NAME	MATERIAL
1.	VALVE BODY	C.I. IS 210 Gr. FG 260
2.	DOME	C.I. IS 210 Gr. FG 260
3.	WEDGE	C.I. IS 210 Gr. FG 260
4.	BODY SEAT RING	BR. IS 318 Gr. LTB2
5.	WEDGE FACE RING	BR. IS 318 Gr. LTB2
6.	STEM	ST. ST. AISI 410
7.	STEM NUT	BR. IS 318 Gr. LTB2
8.	STUFFING BOX	C.I. IS 210 Gr. FG 260
9.	GLAND	C.I. IS 210 Gr. FG 260
10.	GLAND PACKING	JUTE & HEMP IS 5414
11.	HANDWHEEL	C.I. IS 210 Gr. FG 200
12.	FASTENERS	C. ST. IS 1367 Cl. 4.6/4
13.	DOME GASKET	RUBBER IS 638 TYPE B
14.	YOKE SLEEVE	BR. IS 318 Gr. LTB2
15.	STUFFING BOX WITH YOKE	C.I. IS 210 Gr. FG 260
16.	THRUST BEARING	STANDARD
17.	'O' RING	NITRILE RUBBER
18.	SHOE & CHANNEL LINING	BR. IS 318 Gr. LTB2
19.	BACKSEAT BUSH	BR. IS 318 Gr. LTB2
20.	GEARBOX	SPUR GEAR TYPE

RISING STEM SLUICE VALVE WITH HANDWHEEL

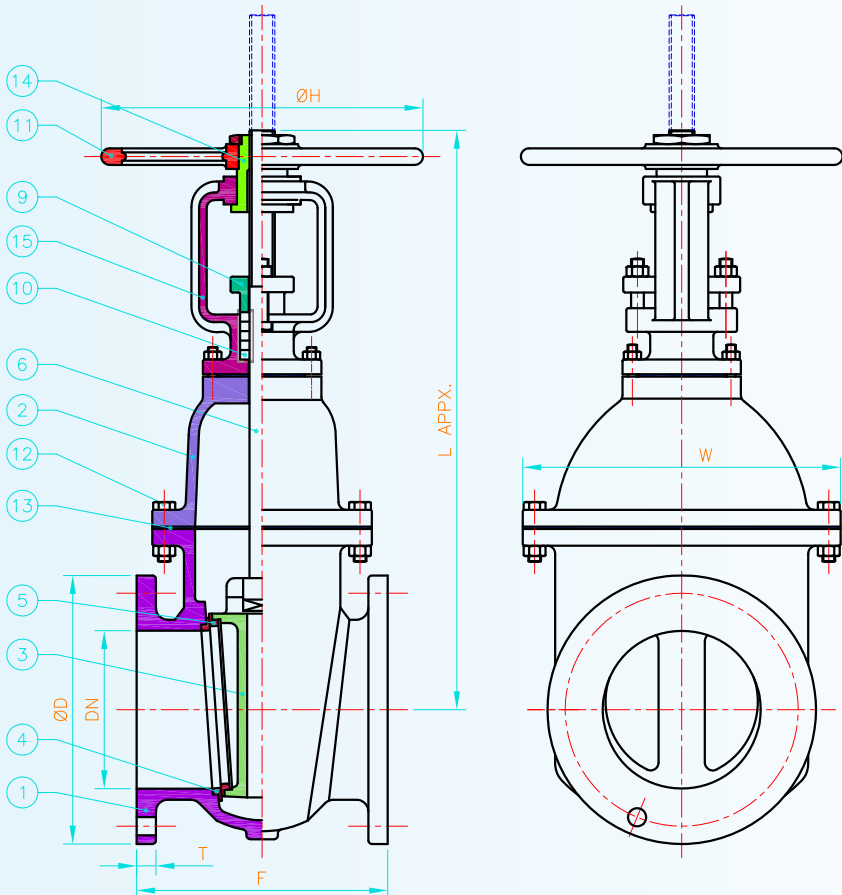

DN (mm)	F	K	W	Ø D	T	Ø H	L
50	178	290	135	165	16	225	290
80	203	360	195	200	21	225	360
100	229	400	235	220	22	320	400
150	267	480	280	285	23	320	480
200	292	610	360	340	24.5	360	610
250	330	690	405	395	26	400	690
300	356	835	490	445	27.5	400	835
350	381	890	555	505	29	500	--
400	406	950	600	565	30	640	--
450	432	1030	640	615	31.5	720	--
500	457	1060	725	670	33	720	--
600	508	1155	925	780	36	720	--

NON RISING STEM SLUICE VALVE WITH SPUR GEARBOX

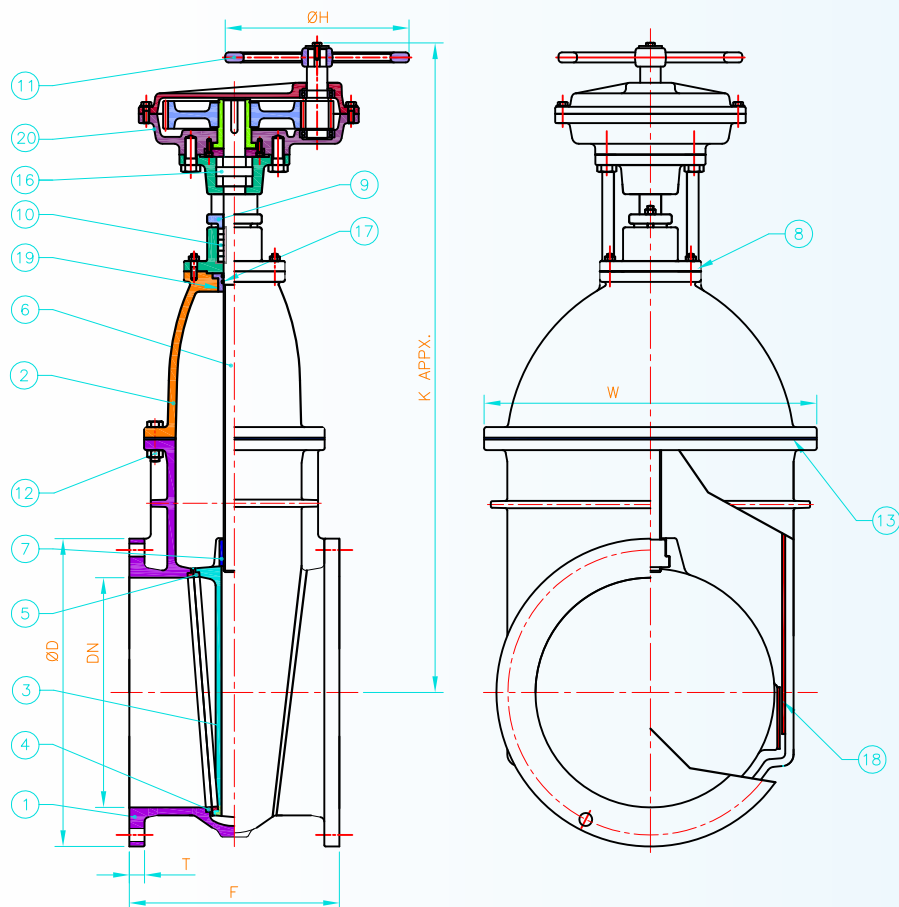

DN (mm)	F	K	W	Ø D	T	Ø H
400	406	1250	600	565	30	400
450	432	1340	640	615	31.5	400
500	457	1420	725	670	33	400
600	508	1600	925	780	36	400
700	610	1960	1015	895	38.5	400
750	610	2100	1090	960	40	400
800	660	2260	1165	1015	41.5	600
900	711	2480	1280	1115	44	600
1000	811	2615	1340	1230	47	600
1100	811	2480	1280	1115	44	600
1200	811	3500	1800	1455	53	600
1500	950	3800	2200	1800	61	800

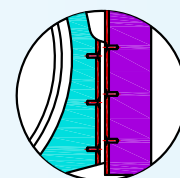

SHOE & CHANNEL FITTING ARRANGEMENT

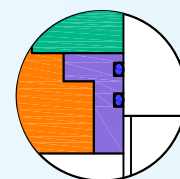

BACKSEAT BUSH ARRANGEMENT

BYPASS ARRANGEMENT

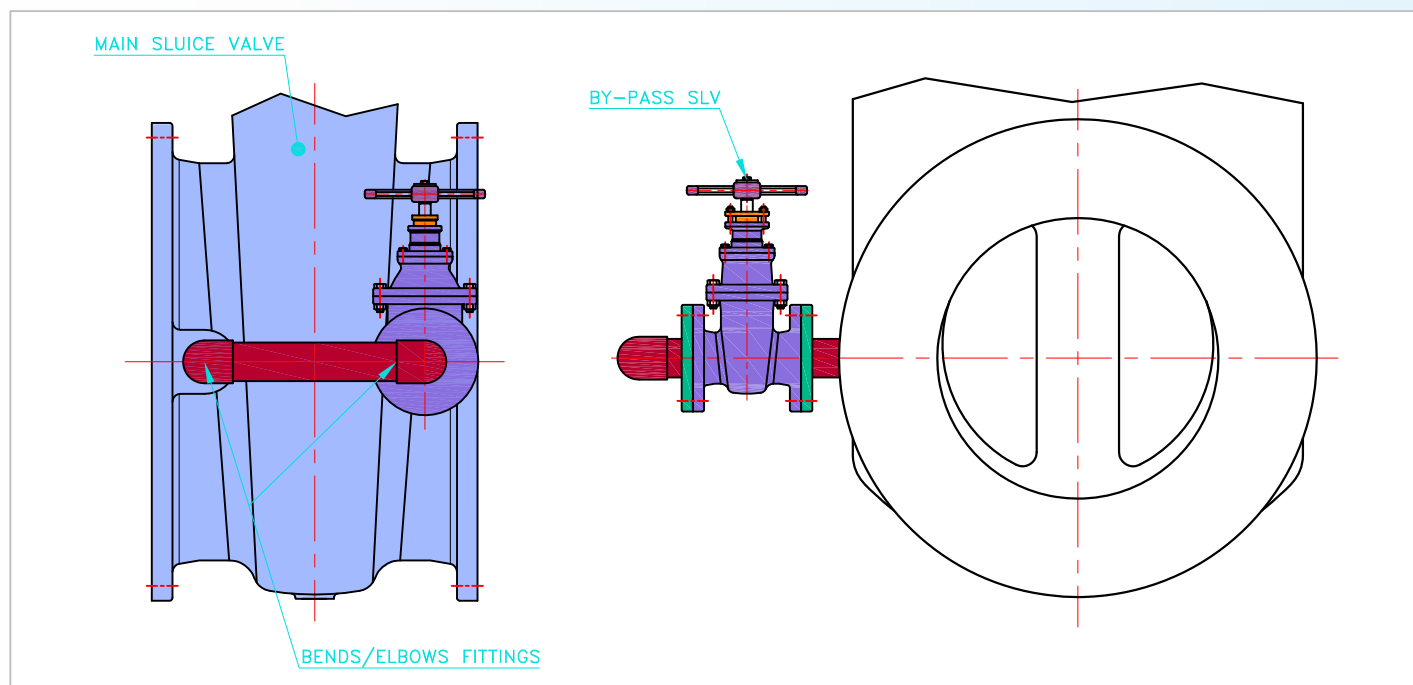

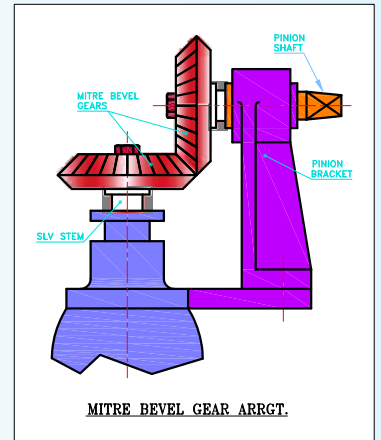
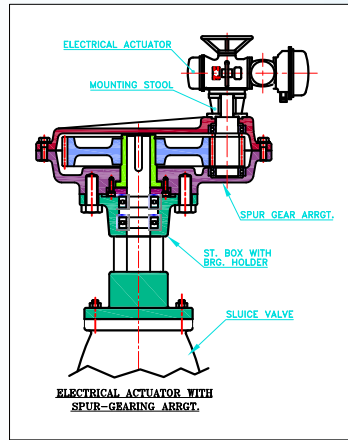
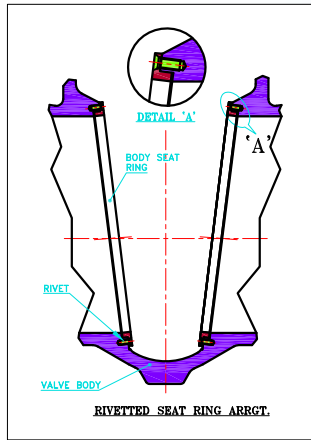
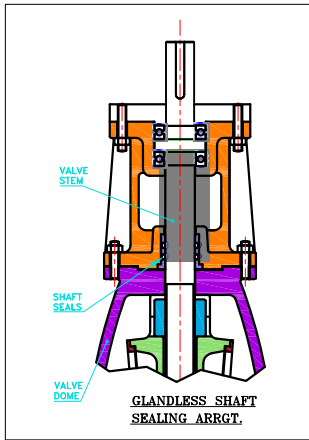

SALIENT FEATURES :

- Sturdy, compact construction.
- Non rising stem (NRSV) & Rising stem (RSGV) construction available.
- Size range: 50 to 1800mm, Pressure ratings: PN 10, PN 16 & PN 25.
- Vertical stem & Horizontal stem (subject to prior confirmation) installations are possible.
- Accessories such as : Gearing (Spur/Bevel), Thrust bearing, Actuators (Electrical / Pneumatic), By-pass, Position indicator, Channel & shoe, Chain-wheel / Cap-Top operation etc. can be offered.
- Wide variety of materials of construction to choose from: Shell : C.I., S.G.I., C.S.(WCB), D2, S.S. , Trim : Bronze, S.S.
- The valves generally conform to IS : 14846 & BS 5163 specifications.

SPECIAL FEATURES :

- Sufficient wear travel allowance on the seats.
- Rivetted seat rings option available.
- Angle fixtures for machining of seat fitting surfaces on body & wedge ensure perfect interchangeability.
- Steam nut with liberal dimensions.
- Glandless construction to avoid tampering & water-loss can also be offered.
- Machine moulded castings of components ensuring perfect soundness, integrity & consistency.

- NOTES: ● All dimensions are in mm unless otherwise specified.
 ● Views and dimensions are typical. They may change in specific cases.



R&D MULTIPLES (METAL-CAST) PVT. LTD.

Head Office : 106, United Industrial Estate, Mogul Lane,
 Mahim, Mumbai 400 016, Maharashtra, India.
 Tel : 4004 4425/26/27/28/29

Plant 1 : A-1/17, GIDC, Pardi - 396 125,
 District Valsad, Gujarat.

Plant 2 : Survey No. 304, Village Balda,
 Pardi - 396 125, District Valsad, Gujarat.

Engineering Division Office : C2-403, Saudamini Complex,
 Srl. No. 101/1, Bhusari Colony, Paud Road, Kothrud, Pune 411 038, India.

E-mail : mumbai@rdmultiples.com

Company & Corporate information, Accreditations Dealer's Stamp